

the ypsilon world



YPSILON

YPSILON

YPSILON

vanity  
doll  
doll damasco  
clever  
cameo  
ghost  
hampton  
gem

1 2 3 4 5 6 7 8

design: Meneghello Paoletti Associati

**vanity** 1 2 3 4 5 6 7 8







*Nella vita ci sono piaceri che ti sei scelta e che dividi con qualcuno di veramente speciale. Come Vanity, il mobile da bagno e insieme da toeletta, con un piano top da 120 cm di diametro.*

*In life, there are pleasures that you choose and pleasures that you share only with someone special. Such as Vanity, a bathroom and toiletry cabinet with a 120 diameter top.*



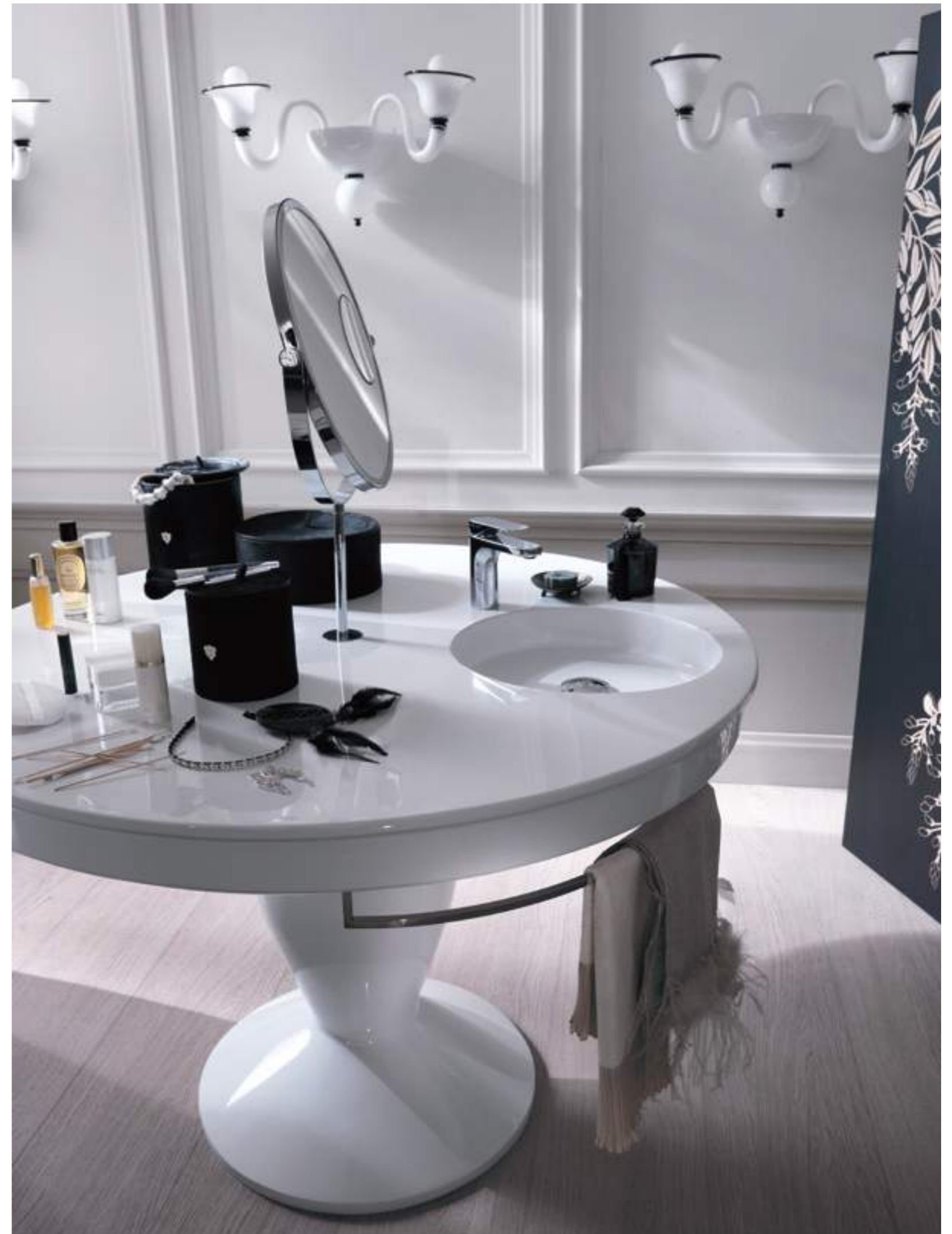











*Ora, in questa stanza, riluce un gioiello di design.  
Molto femminile la linea della gamba di sostegno  
centrale su cui poggia il piano con lavabo ad  
incasso e le scatole porta-oggetti.*

*Now, in this room, shines a jewel of design.  
The line of the central column is very elegant  
and it supports the top with a built-in basin  
and storage boxes.*









*È scoprire che la vita è più bella con Vanity, strutturato per darti la giusta dose di funzionalità e spensieratezza. Preziose scatole in pelle cucite a mano dalle diverse tonalità e dimensioni, sono come un gioco effimero.*

*Life is more beautiful with Vanity, designed to provide you functionality and comfort. Precious hand-stitched leather boxes with different shades and sizes that can be positioned as you like.*



design: Meneghello Paoelli Associati

**doll** 1 2 3 4 5 6 7 8







*In ogni oggetto che possiedi c'è un po'  
della tua anima, una traccia della tua esistenza  
vitale. Doll è parte di te, dei tuoi gesti quotidiani,  
del tuo mondo privato.  
La sua eleganza ti sorprende ogni volta che lo  
guardi. La sua linea è decisa ed essenziale,  
preziosa l'architrave.*

*In every object that you have, there is  
a piece of you, a trace of your vital existence.  
Doll is a part of you, of your daily gestures,  
of your private world. Its elegance surprises  
you every time you look at it.  
Its line is strong and special, a precious lintel.*













*Per il sistema bagno puoi scegliere lavabi da appoggio o incorporati, top in cristallo, marmo o consolle in resina. C'è un ampio spazio per contenere tutto quello che vuoi. Le ante con guide slider si aprono e si chiudono in silenzio.*

*For your bathroom, you can choose standard or built-in basins, tops made of glass, marble or resin. There is plenty of space to keep everything you want. The doors with slider guides open and close silently.*













*Doll è un mobile talmente versatile che puoi personalizzarlo come più ti piace, optando tra infinite rifiniture in legno e colori, con una gamma composta di varianti.*

*Doll is a very versatile cabinet that you can customize as you like, choosing among a number of wooden finishing and colours as well as versions.*





design: Meneghello Paoletti Associati

**doll damasco** 1 2 3 4 5 6 7 8







*C'è un periodo in cui tutto ti sembra immobile nella sua perfezione, come se il tempo non fosse in movimento ma fissato sull'immagine di un mobile bagno di gran lusso. Oggetto sensuale, Doll Damasco, ricco di particolari insoliti, di cui ammira la ricercatezza e il valore.*

*There are moments when everything seems frozen in its perfection, as if time stopped moving and fixed itself on the image of a luxurious cabinet. An elegant cabinet rich in unconventional details that excite your admiration.*















*Una griglia ornata in un bagno d'oro o d'argento caratterizza questo sistema bagno, pregiato anche per la sua funzionalità: piano e lavabo in marmo, gambe nere laccate lucide, contenitore ampio e curato in ogni dettaglio.*

*A golden or silver-plated grid characterizes this cabinet, prized also for its functionality: a marble top and basin, bright lacquered black legs, a large and painstaking made cabinet.*

design: BB Associati

**clever** 1 2 3 4 5 6 7 8







*Se il tuo mondo è pieno di sogni e di desideri,  
se il tuo motto è originalità nella quotidianità,  
se la curiosità è parte del tuo stile,  
Clever è il tuo mobile bagno. Impredicabile con  
il lavabo triangolare e classico con il piano top  
dalle essenze più pregiate. (Qui è in legno di ulivo)*

*If your world is full of dreams and wishes,  
if your motto is originality in daily life,  
if curiosity is a characteristic of yours,  
Clever is the cabinet for you.  
Unconventional triangular basin and classic  
top made of the most precious materials.  
(In the picture, the top is made of olive tree)*











design: Meneghello Paoelli Associati

**cameo** 1 2 3 4 **5** 6 7 8







*La felicità è sempre dietro l'angolo.  
Socchiudi gli occhi e riconosci il tuo Cameo,  
e ancora una volta ti lasci affascinare dalla  
sua forma aggraziata e dal suo prezioso  
frontale in capitonné o matelassé.*

*Happiness is always around the corner.  
Close your eyes and recognize your Cameo and,  
for once, let yourself be captured by  
the elegant shape of Cameo with its padded  
or quilted front.*







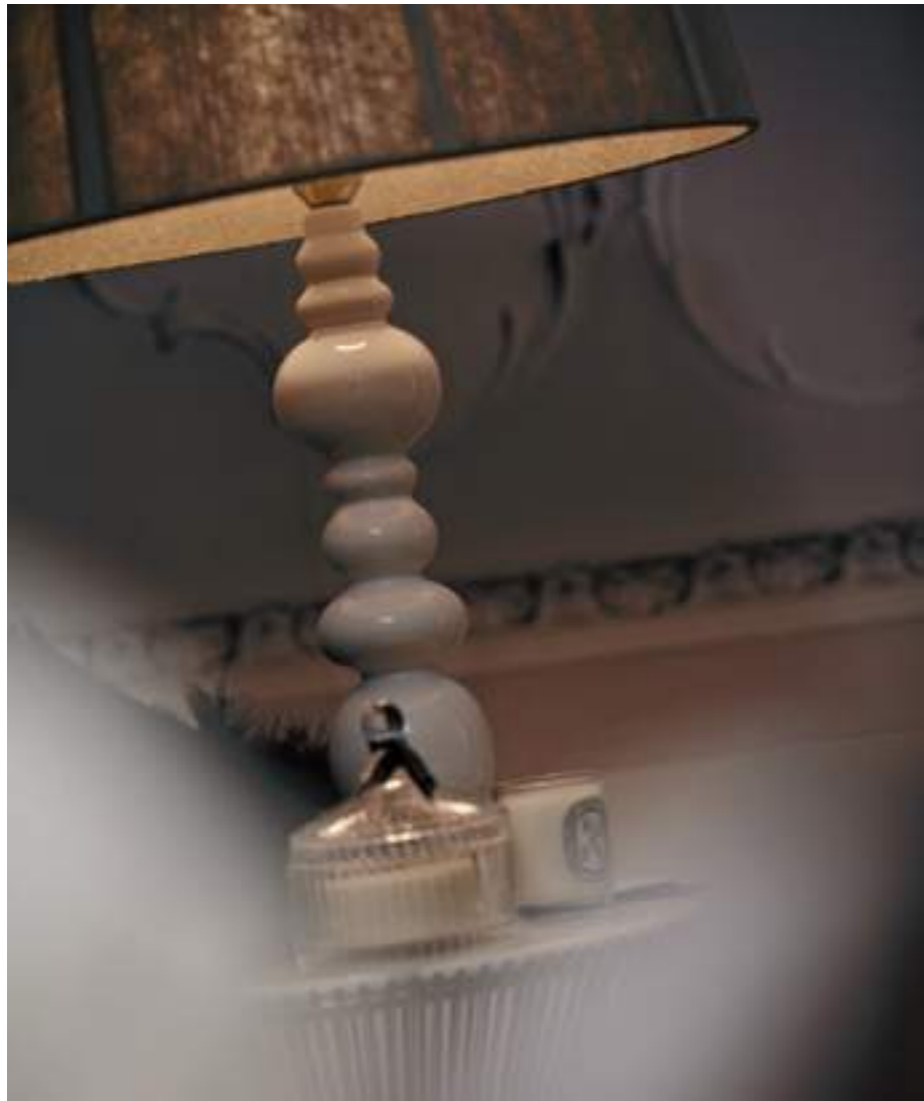



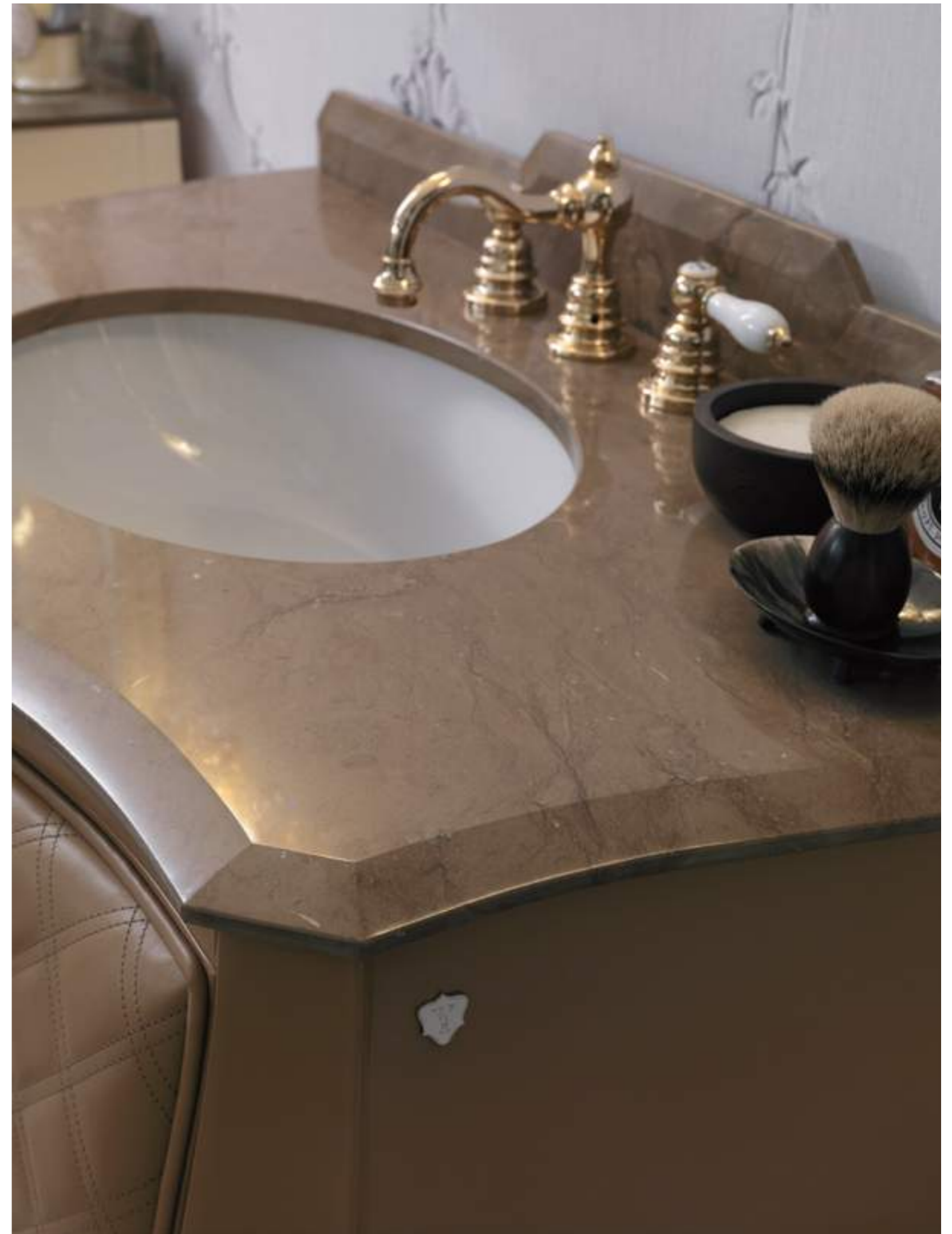





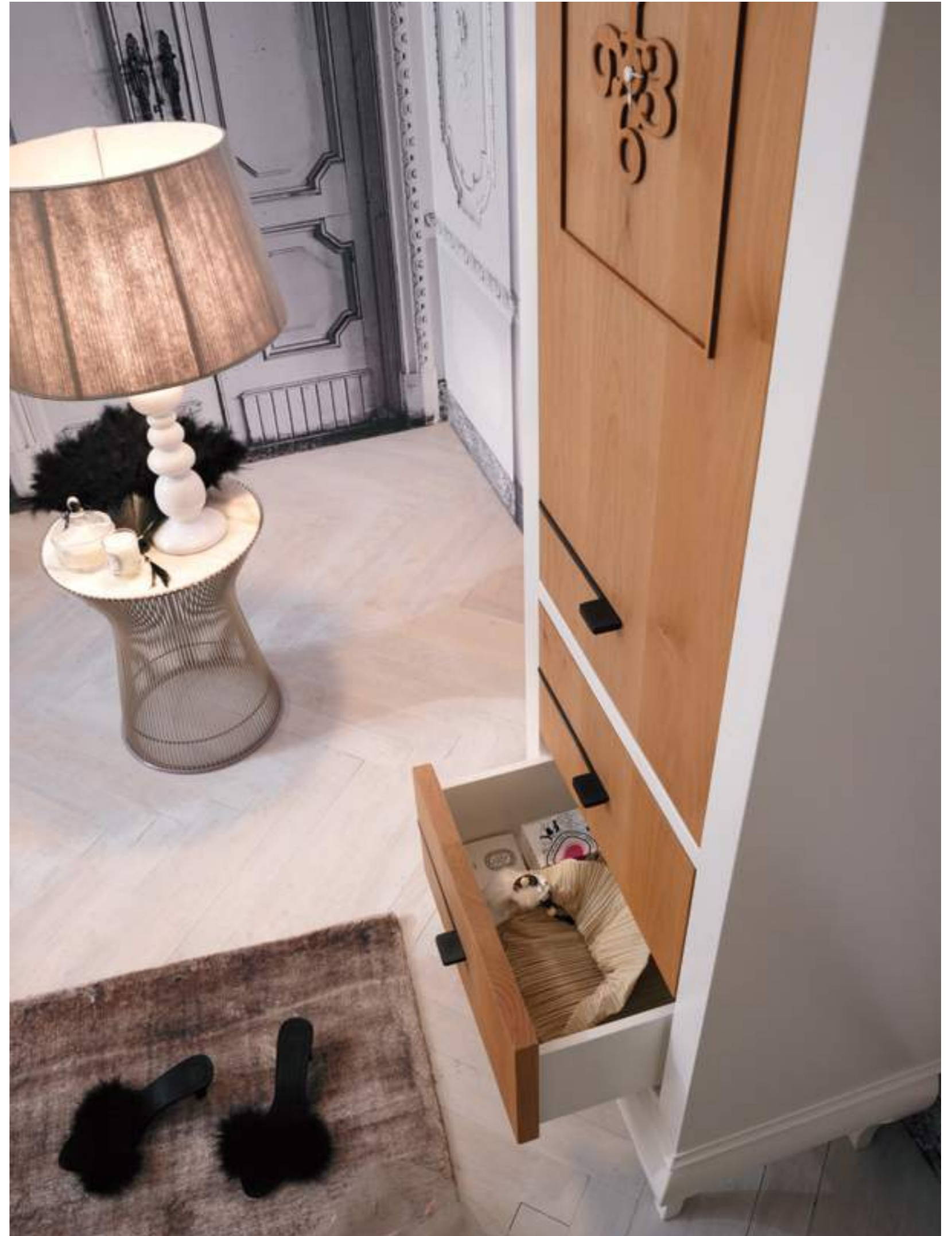











*Legni pregiati, piano in marmo dalle venature sempre diverse, guide soft per i cassetti, rivestiti in velluto con passamanerie ricercate: in Cameo la bellezza si può ammirare e toccare.*

*Precious woods, a marble top of different hues, soft close drawers lined in velvet with elegant trimmings: with Cameo, you can both admire and touch beauty.*

design: Meneghello Paoletti Associati

ghost 1 2 3 4 5 6 7 8







*Ghost è la tua visione mentale che prende forma in un sistema bagno di estrema eleganza. Laccature chic in una vasta gamma di colori, top in vetro o in marmo, cassetti rivestiti in velluto con passamanerie uniche e maniglie con il logo Y. Raffinatissimo!*

*Ghost is your mental vision that takes the form of an extremely elegant bathroom. Refined lacquering in a wide range of colours, glass or marble tops, drawers lined in velvet and unique trimmings and handles with Y logo. Very elegant!*













*La struttura posteriore di Ghost è particolare: in vetro a specchio con un secondo specchio contenitore al centro. Una caratteristica che lo rende un pezzo unico, se personalizzato da te.*

*Ghost's back structure is very particular; the mirror-glass contained a second mirror in the centre that can hold objects. This customizable feature makes it a unique piece.*









design: BB Associati

**hampton** 1 2 3 4 5 6 **7** 8











*Avevi sentito la storia, a frammenti, da varie persone e, come spesso accade in casi simili, era una storia diversa.*

*Se conosci Hampton, conosci anche come è fatto. A regola d'arte. Il mobile si presenta in due versioni: Hampton 100 in rovere europeo fumé e 180 in rovere chiaro.*

*You've heard the story in pieces from different people and, as it often happens, it was a different story. If you know Hampton, you know how it is made: perfectly. The cabinet comes in two versions: Hampton 100 made of dark European durmast and Hampton 180 of light durmast.*













*Entrambi i modelli sono dotati di piano in marmo o Korakril. Tantissimi i cassetti push-pull nel cui interno, giallo ocra laccato, è impresso il logo Y su un fondo di crosta cerata. Un dettaglio che lo valorizza nel suo essere contenitore straordinario.*

*Both models are equipped with marble or Korakril top. Lots of push-pull drawers with lacquered yellow ochre interiors and a Y logo branded on the waxed crust leather bottom. A detail that makes it one-of-a-kind.*











*La storia di Hampton si poggia sulle sue gambe: in rame con una struttura leggera ma solida che si ispirano all' High Voltage. Hampton trasforma la tua stanza da bagno in luogo ideale dove assaporare i piccoli piaceri quotidiani.*

*The story of Hampton is told by its legs made of copper with a light, but strong, frame inspired by High Voltage. Hampton turns your bathroom in an ideal place where you can enjoy daily pleasures.*

design: Meneghello Paoletti Associati

gem 1 2 3 4 5 6 7 8









*Come acqua che danza in una vasca satinata.  
Come un diamante, le cui sfaccettature  
gli conferiscono un tocco di classe.  
Come una chimera monolitica, il cui blocco  
unico di marmo è venato da effetti naturali.  
È Gem, nuovo, inconsueto, glamour.*

*Like dancing water in a silky bath or a  
multi-faceted diamond with its special touch  
of class. Like a monolithic chimera made from  
a single marble block that has been veined by  
nature. This is Gem, new, unusual and glamorous.*

**tech specs** ▾ G D DD C CG H

vanity

ghost

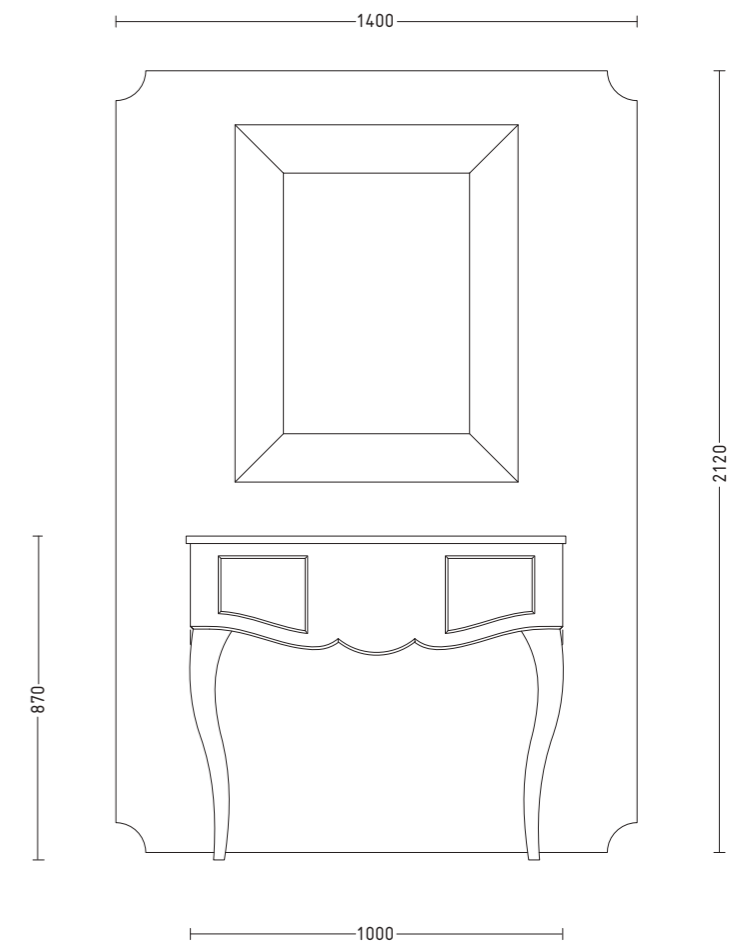
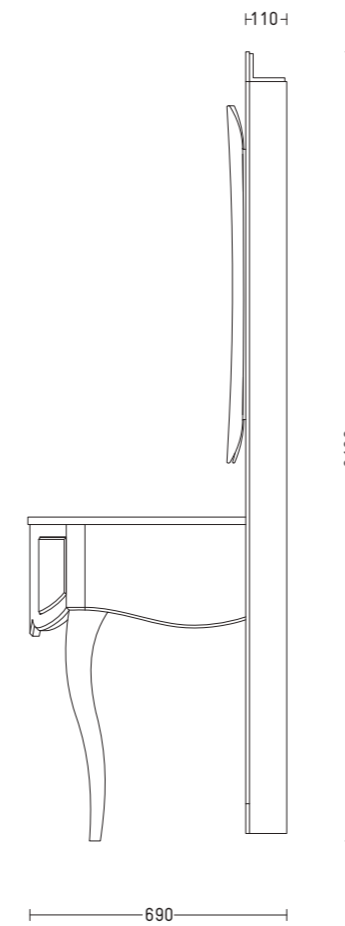
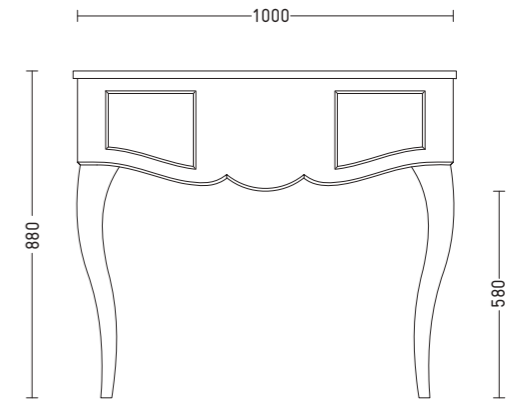
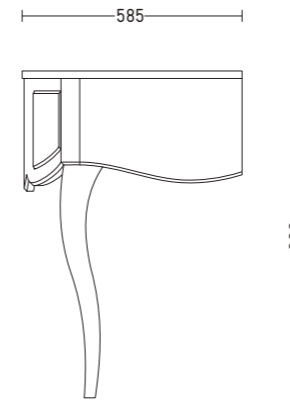
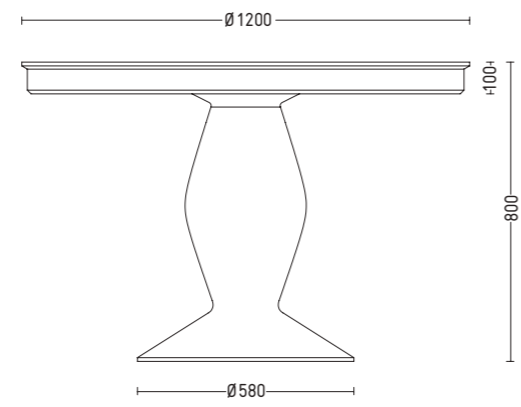
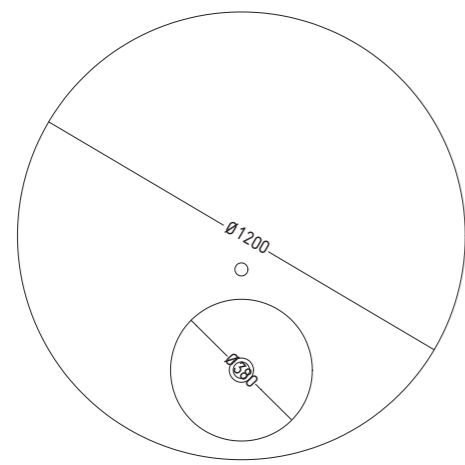

# doll

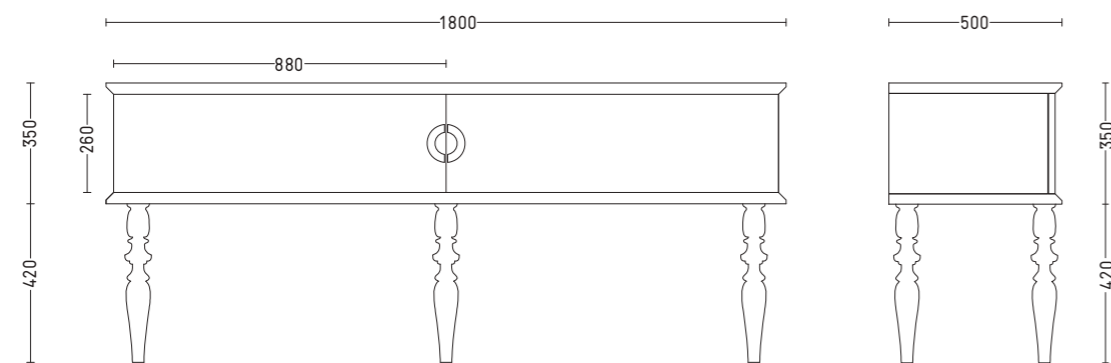
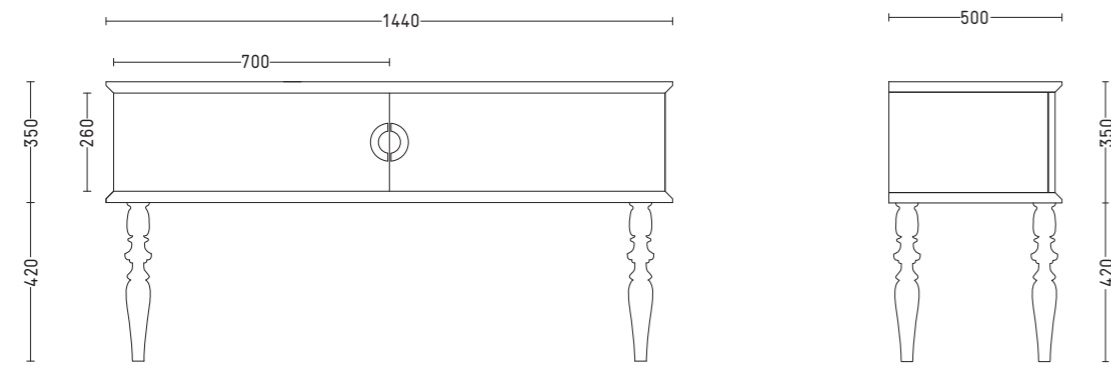
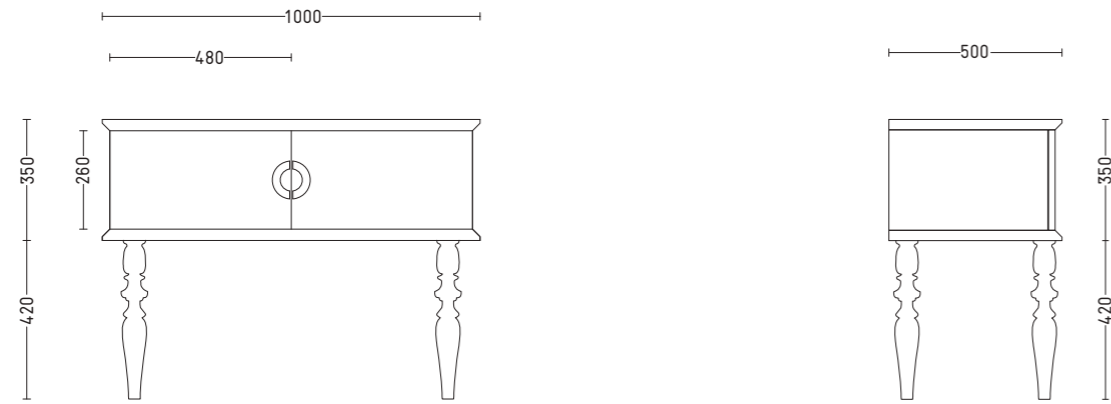

# doll cabinet

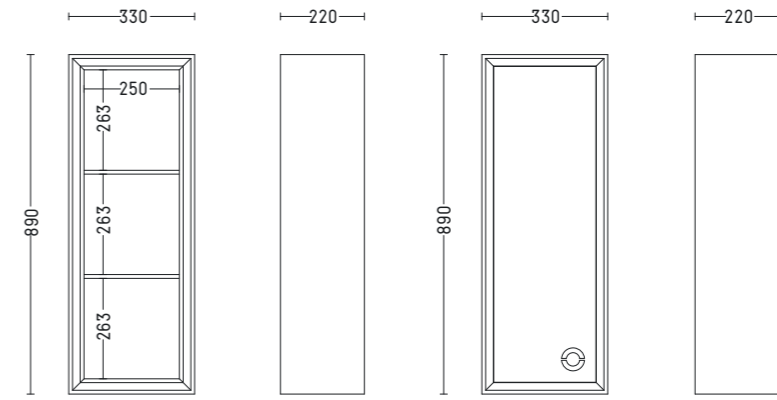

# doll armadio

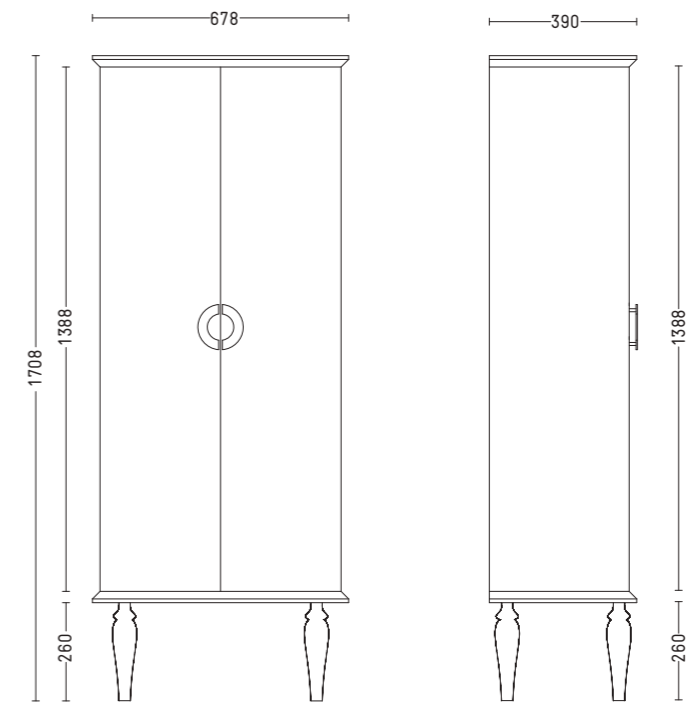

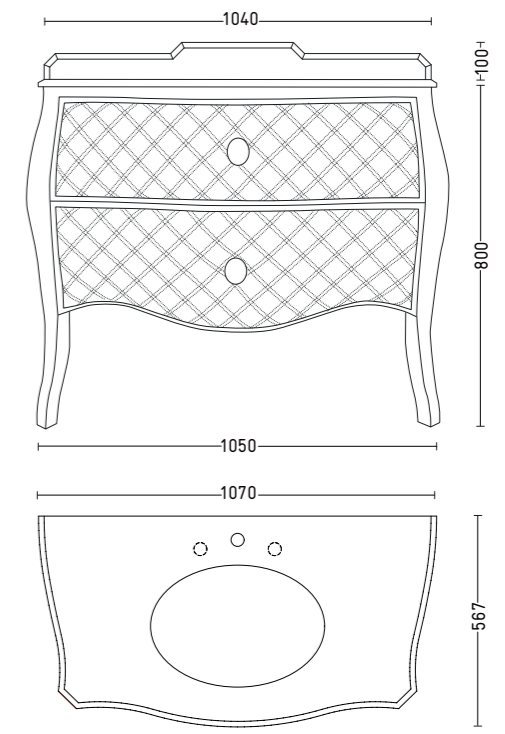
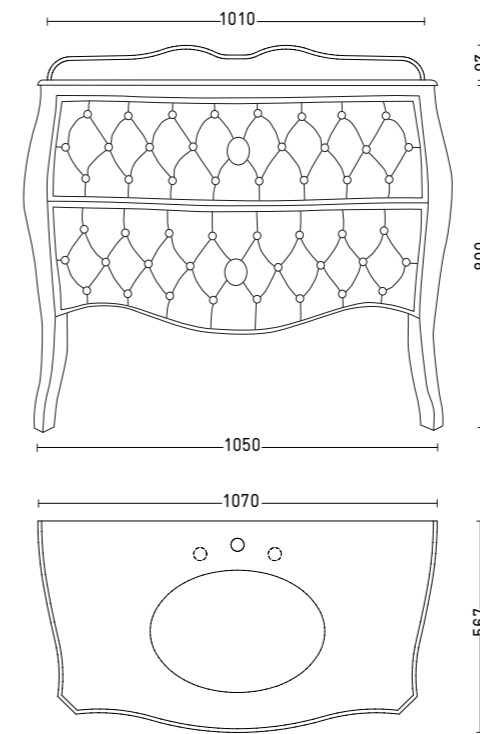
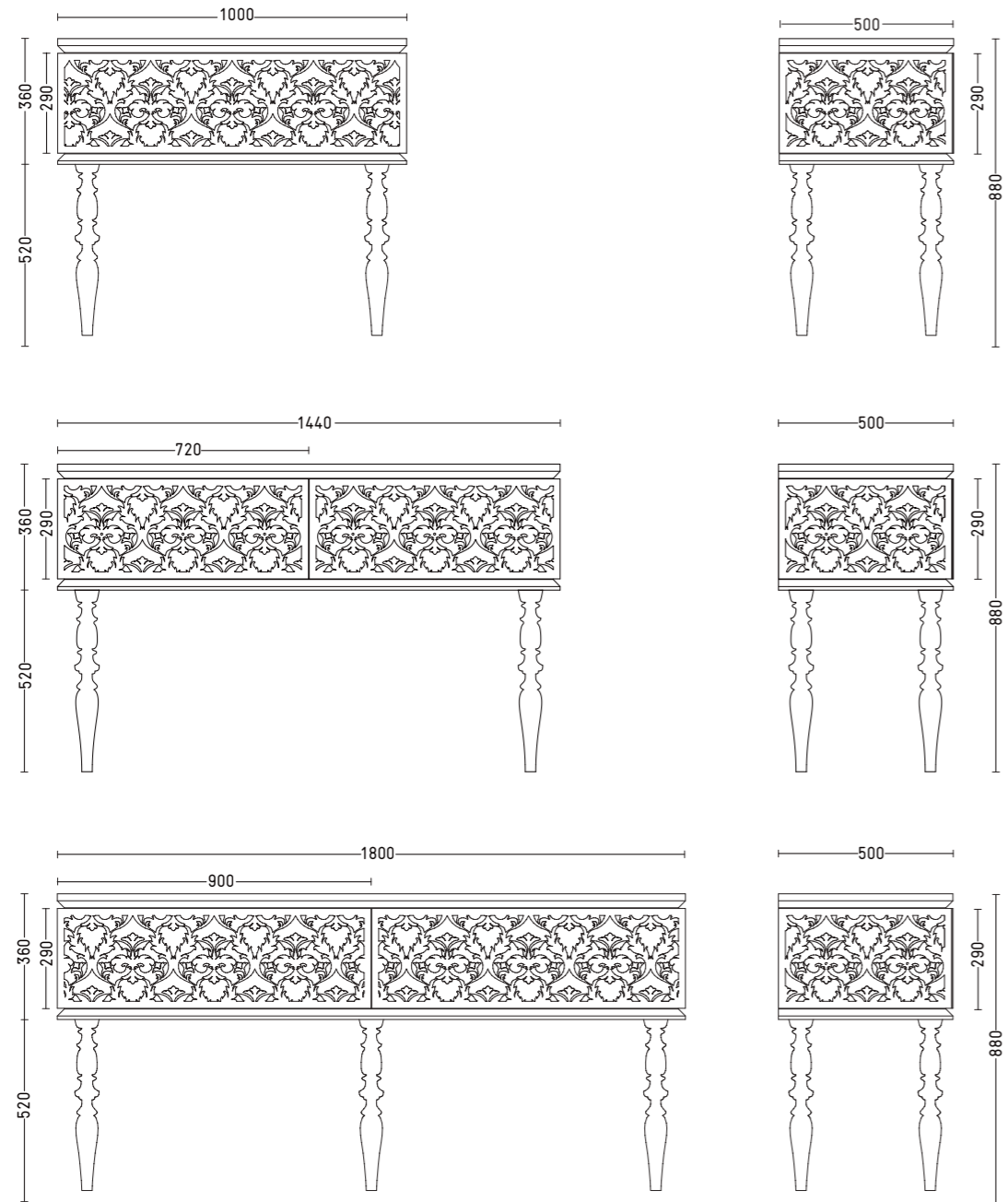

clever

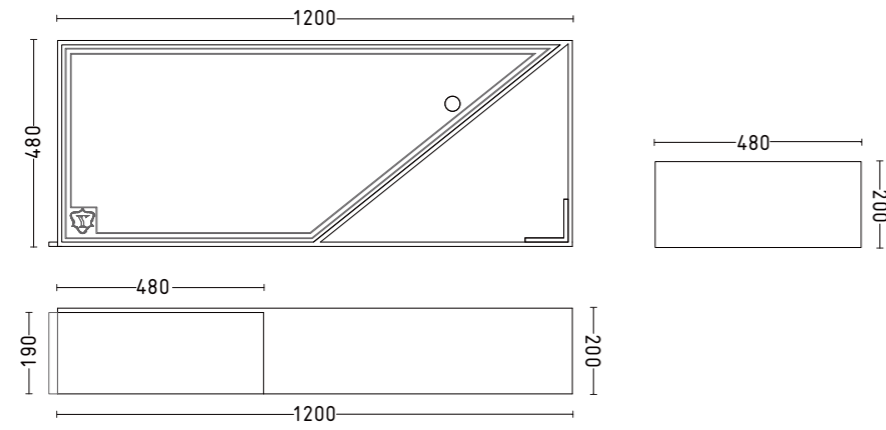

hampton

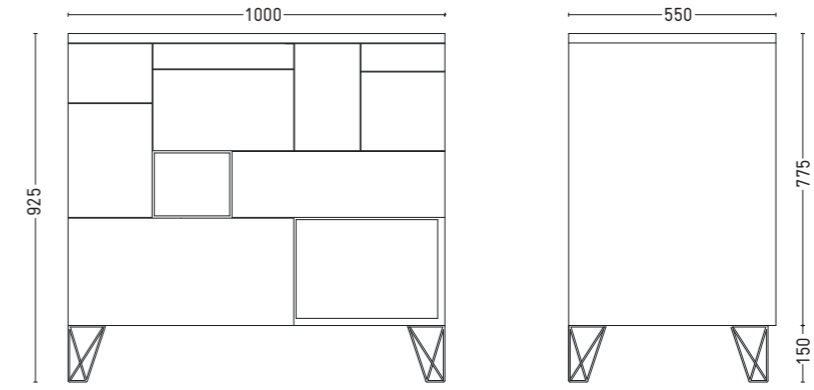

gem

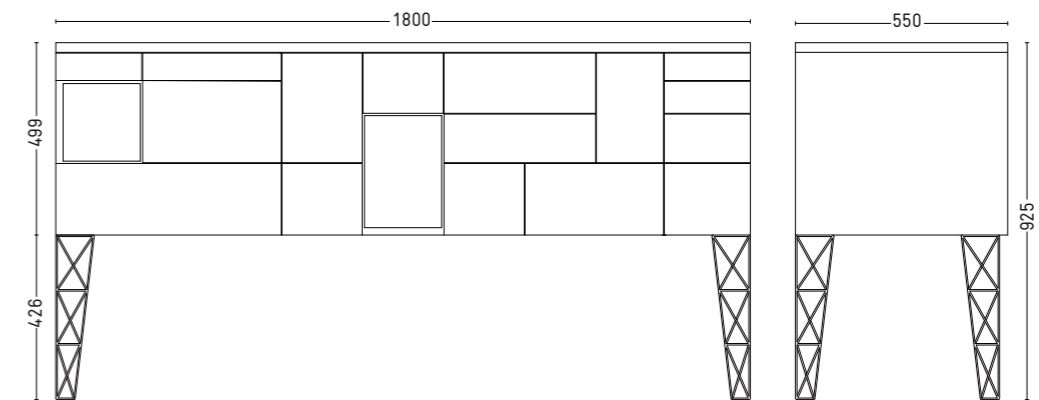
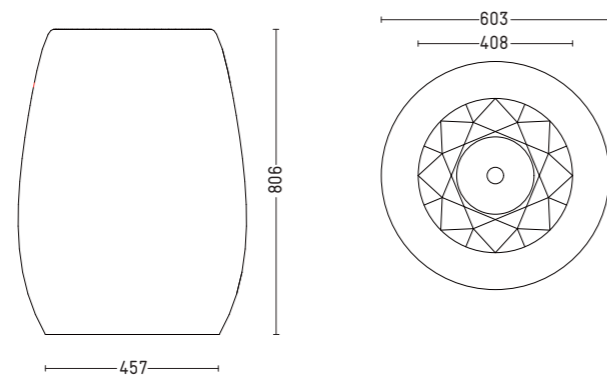

**finishes** C ∇ L M W C



# glossy&matt colours

# velvets

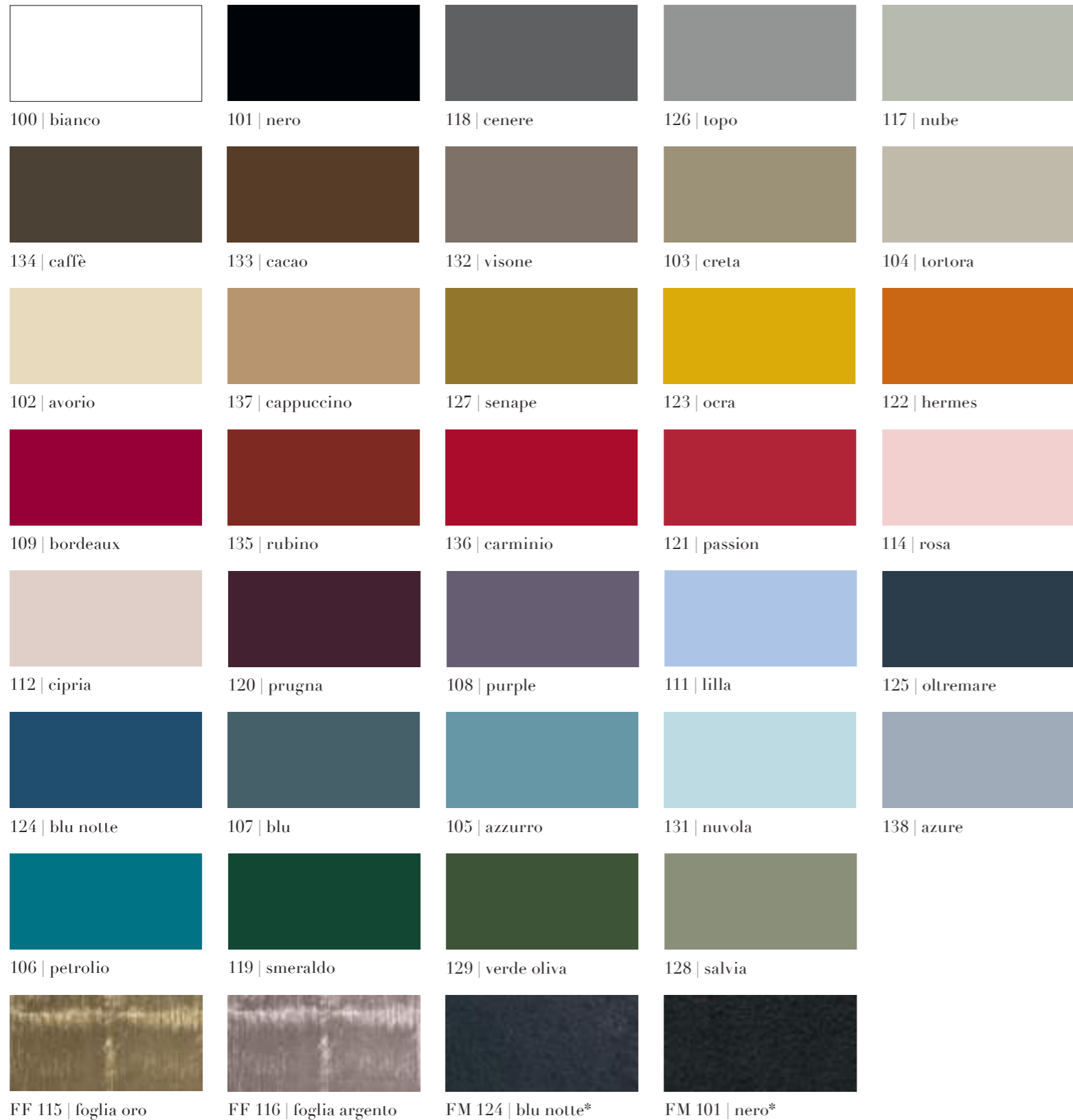

\* The "PEARL" finish is available for all colours

\*\* Colours shown are for reference only

\*\*\* FL glossy finished | FO matt finished

\* Colours shown are for reference only

# leathers\*



400 | white



401 | lamb



403 | rosa



402 | azure



408 | graphite



414 | frost



409 | cappuccino



415 | earth



410 | oceania



407 | black



405 | liz



404 | phonebox



411 | ocre



412 | lime



413 | turquoise



406 | serpentine

# marbles

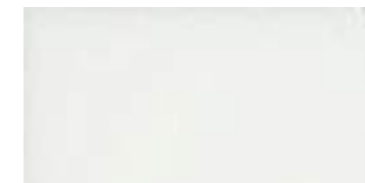

210 | ming white



202 | bianco scintillante



201 | bianco calacatta

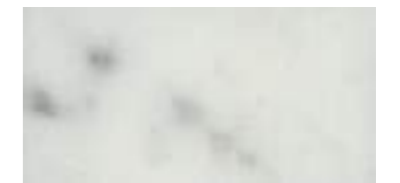

200 | bianco carrara



203 | nero marquinia



204 | nero del belgio



213 | nero saint laurent



219 | grey saint laurent



206 | rosa portogallo



208 | travertino sunflower



209 | travertino dorato



214 | travertino noce in falda



218 | warm gray



215 | grigio tao



216 | ebano



217 | chocolate



207 | verde guatemala



220 | verde alpi



221 | bardiglio nuvolato



222 | rosso francia

\* The texture of the skin is always variable

\* Colours shown are for reference only

\* Colours shown are for reference only

# finishes wood



600 | rovere sbiancato



601 | rovere nazionale



602 | rovere americano fumé



603 | rovere europeo fumé



604 | rovere europeo naturale  
604 ts | rovere europeo naturale



609 | rovere chiaro



608 | ulivo



607 | ciliegio americano



605 | noce canaletto naturale  
605 ts | noce canaletto naturale



606 | noce nazionale a foglia aperta



500 | noce | colour wood



501 | ciliegio | colour wood



502 | mogano | colour wood



503 | noce anticato | colour wood



504 | ciliegio anticato | colour wood

\* Colours shown are for reference only  
\*\* ts | taglio sega

# crystals

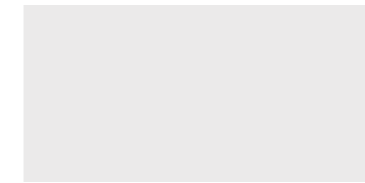

300 | bianco



301 | nero



308 | antracite



303 | argento



307 | blu atlantico



306 | celeste



305 | verde



304 | acquamarina



311 | melanzana



313 | rosa orchidea



316 | rosso granata



309 | rosso rubino



310 | cacao



312 | canapa



315 | beige

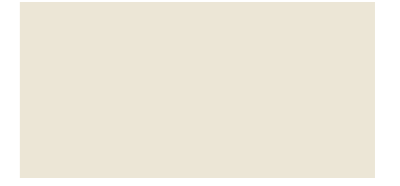

302 | avorio



314 | tortora

\* Colours shown are for reference only

## thanks to:

Δlf Uno  
Δhura  
Δrt Ceram  
Δzzurra Sanitari in Ceramica  
Carella  
C.F. Light Division  
Doimo Sofas  
Fabbian Illuminazione  
Fima Carlo Frattini  
Fir Italia  
Lèndilegno by Gierre +ranciati  
Prearo Collezione Luce  
Rexa Design  
Stillux Illuminazione  
Votolina - Classic Light  
OF Interni

art director  
donatella bottacin  
vittorio bottacin

photo  
studio rocci

stylist  
02 studio

Ypsilon  
Strada Battaglia, 119  
35020 Albignasego [PD] Italy  
t. +39 049 9866700  
info@ycollection.it

[www.ycollection.it](http://www.ycollection.it)

